

# POWERMMASTER<sup>TM</sup> SERIES

## OPERATING, SERVICE AND MAINTENANCE MANUAL

By **RAMSEY**

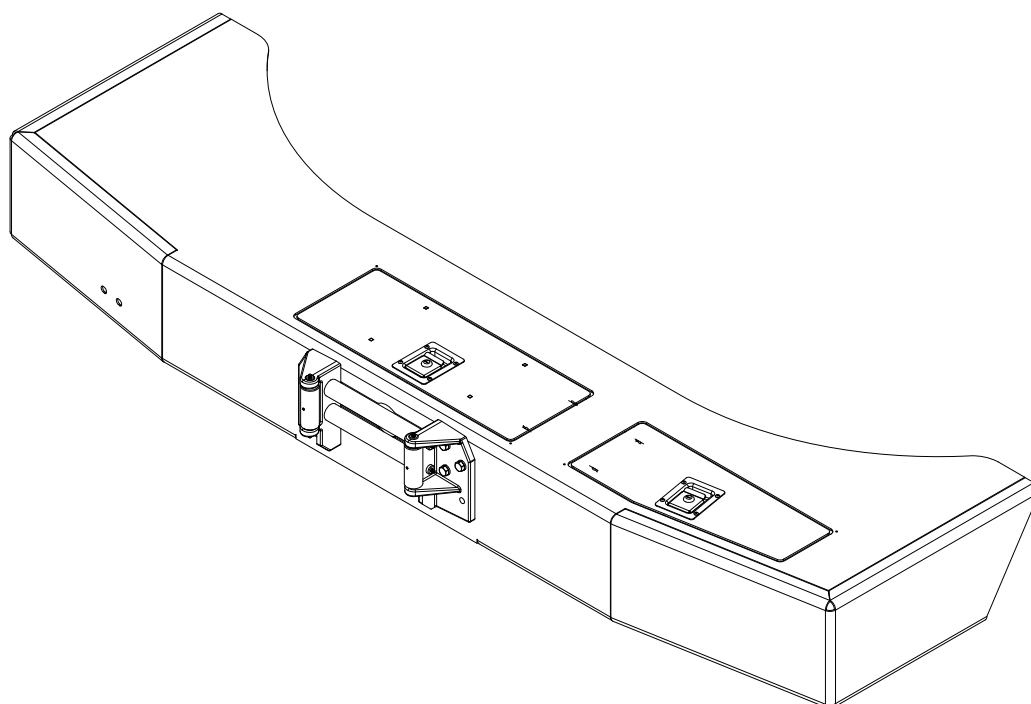

## POWERMMASTER SERIES 20,000 LB INDUSTRIAL WINCH AND BUMPER



**CAUTION:** READ AND UNDERSTAND THIS MANUAL BEFORE INSTALLATION AND OPERATION OF WINCH. SEE WARNINGS!

**RAMSEY  
WINCH**

## TABLE OF CONTENTS

<b>INTRODUCTION .....</b>	<b>1</b>
<b>WARRANTY INFORMATION .....</b>	<b>1</b>
<b>SPECIFICATIONS.....</b>	<b>1</b>
<b>WARNINGS.....</b>	<b>1</b>
<b>CABLE INSTALLATION.....</b>	<b>2</b>
<b>HYDRAULIC SYSTEM REQUIREMENTS.....</b>	<b>3</b>
<b>PERFORMANCE CHARTS .....</b>	<b>3</b>
<b>CLUTCH OPERATION .....</b>	<b>4</b>
<b>WINCH OPERATION .....</b>	<b>4</b>
<b>MAINTENANCE .....</b>	<b>4-5</b>
<b>TROUBLESHOOTING GUIDE .....</b>	<b>5</b>
<b>INSTRUCTIONS FOR DISASSEMBLY.....</b>	<b>6-14</b>
<b>PARTS LIST AND PART DRAWING.....</b>	<b>15-17</b>
<b>LIMITED WARRANTY .....</b>	<b>18</b>

# RAMSEY HYDRAULIC PLANETARY WINCH MODEL POWERMASTER 20K

## PLEASE READ THIS MANUAL CAREFULLY

This manual contains useful ideas in obtaining the most efficient operation from your Ramsey Winch, and safety procedures one needs to know before operating a Ramsey Winch. Do not operate this winch until you have carefully read and understand the "WARNINGS" and "OPERATION" sections of this manual.

## WARRANTY INFORMATION

Ramsey Winches are designed and built to exacting specifications. Great care and skill go into every winch we make. If the need should arise, warranty procedure is outlined on the back of your self-addressed postage paid warranty card. Please read and fill out the enclosed warranty card and send it to Ramsey Winch Company. If you have any problems with your winch, please follow instructions for prompt service on all warranty claims. Refer to back page for limited warranty.

## SPECIFICATIONS\*

Rated Line Pull (lbs.) .....						20,000
(Kg.) .....						9070
Gear Reduction .....						21:1
Weight (without cable) 20K Bumper Winch (Less Bumper).....						337 lbs
<b>LAYER OF CABLE</b>		<b>1</b>	<b>2</b>	<b>3</b>	<b>4</b>	<b>5</b>
*Rated line pull per layer	lbs.	20,000	17,300	15,200	13,600	12,300
	Kg.	9,070	7,840	6,890	6,160	5,570
* Cable Capacity per Layer						
20K Winch	ft.	30	70	115	165	220
	m	9	21	35	20	67
* Line Speed (at 30 GPM)	FPM	42	47	53	59	65
	MPM	12.1	13.6	15.5	17	18.8
* These specifications are based on recommended wire rope of 9/16" Extra Improved Plow Steel and a 14.9 cu. in. / Rev. motor.						

**NOTE:** The rated line pulls shown are for the winch only. Consult the wire rope manufacturer for wire rope ratings.

## **WARNINGS:**

**CLUTCH MUST BE FULLY ENGAGED BEFORE STARTING THE WINCHING OPERATION.**

**DO NOT START WINCH MOTOR BEFORE ENGAGING CLUTCH.**

**DO NOT DISENGAGE CLUTCH UNDER LOAD.**

**STAY OUT FROM UNDER AND AWAY FROM RAISED LOADS.**

**STAND CLEAR OF CABLE WHILE PULLING. DO NOT TRY TO GUIDE CABLE.**

**DO NOT EXCEED MAXIMUM LINE PULL RATINGS SHOWN IN TABLE.**

**DO NOT USE WINCH TO LIFT, SUPPORT, OR OTHERWISE TRANSPORT PEOPLE.**

**A MINIMUM OF 5 WRAPS OF CABLE AROUND THE DRUM BARREL IS NECESSARY TO HOLD THE LOAD.**

**CABLE ANCHOR IS NOT DESIGNED TO HOLD LOAD.**

## CABLE INSTALLATION

1. Unwind cable by rolling it out along the ground to prevent kinking. Securely wrap end of wire rope, opposite hook, with plastic or similar tape to prevent fraying.
2. Place taped end of cable into hole in cable drum as shown below. Use 3/8"-16NC X 3/8" Lg. Hx socket drive setscrew to secure cable to drum.
3. Carefully run the winch in the "reel-in" direction. Keeping tension on end of cable, spool all the cable onto the cable drum, taking care to form neatly wrapped layers.

After installing cable, check freespool operation. Disengage clutch and pull on cable at walking speed. If cable "birdnests", loosen jam nut #30 and turn 3/8"-16NC capscrew #26 clockwise to increase drag on drum. If cable pull is excessive, loosen 3/8"-16NC capscrew #26 by turning counterclockwise. Tighten jam nut when proper setting is obtained.

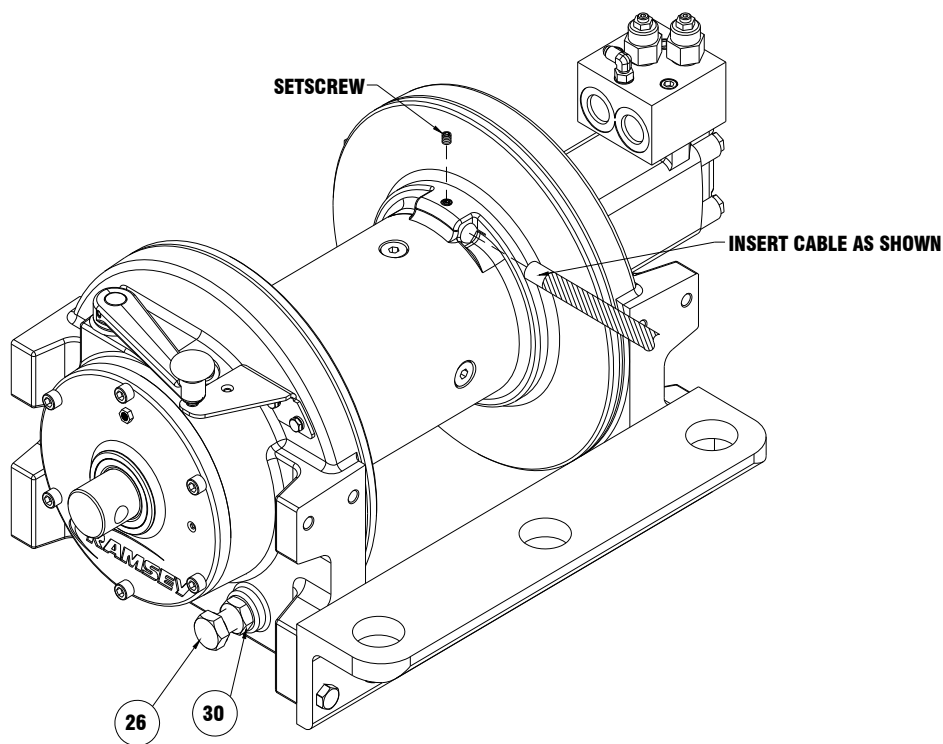

## HYDRAULIC SYSTEM REQUIREMENTS

Refer to the performance charts, below, to properly match your hydraulic system to the Powermaster 20K winch performance. The charts consist of:

- (1) Line pull (lb.) first layer vs. working pressure (PSI) and (2) Line speed, first layer (FPM) vs. gallons per minute (GPM). Performance based on a motor displacement of 14.9 cubic inches with 30 GPM maximum flow rate. Motor has (2) 1.062-12 SAE straight thread o-ring ports.

**Note: A motor spool (open center) directional control valve is required for brake operation.**

## TYPICAL LAYOUT

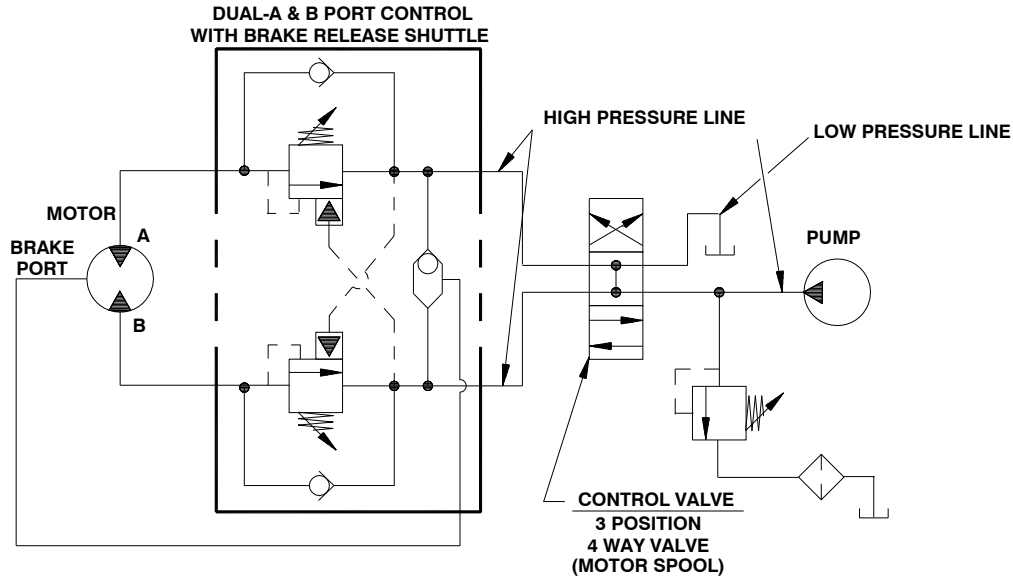

## PERFORMANCE CHARTS

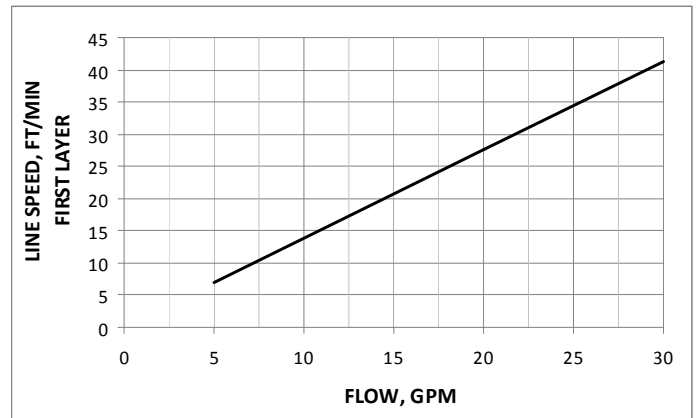
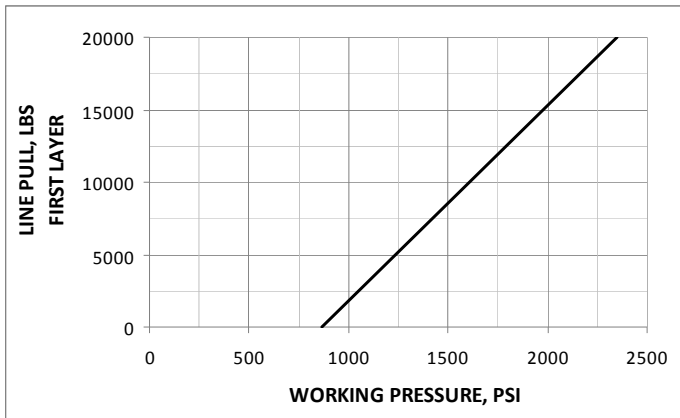

**BASED ON 14.9 CU IN/REV MOTOR**

## **CLUTCH OPERATION**

**WARNING: CLUTCH MUST BE FULLY ENGAGED BEFORE STARTING THE WINCHING OPERATION.**

### **To engage clutch:**

1. Grasp shift lever and push toward drum to the "In" position.
2. If shift lever detent does not engage to the detent hole, then the clutch is not fully engaged. The cable drum may need to be manually rotated slightly while pushing on the shift lever to align the clutch splines.

**WARNING: DO NOT DISENGAGE CLUTCH UNDER LOAD.**

### **To disengage clutch:**

1. Run the winch in the "cable out" direction until the load is off the cable.
2. Grasp the shift lever and pull away from drum to the "Out" position until shift lever detent engages in detent hole. If there is resistance in moving the shift lever, the cable drum may be manually rotated in the cable "Out" direction thereby relieving the preload and allowing the lever to shift. The cable may now be pulled off by hand.

## **WINCH OPERATION**

The best way to get acquainted with how your winch operates is to make test runs before you use it. Plan your test in advance. Remember, you hear your winch, as well as see it operate; learn to recognize the sounds of a light steady pull, a heavy pull, and sounds caused by load jerking or shifting. Gain confidence in operating your winch and its use will become second nature with you.

The uneven spooling of cable, while pulling a load, is not a problem, unless there is a cable pileup on one end of drum. If this happens reverse the winch to relieve the load and move your anchor point further to the center of the vehicle. After the job is done you can unspool and rewind for a neat lay of the cable.

## **MAINTENANCE**

Adhering to the following maintenance schedule will keep your winch in top condition and performing as it should with a minimum of repair.

### **A. WEEKLY**

1. Check the oil level and maintain it to the oil level plug. If oil is leaking out, determine location and repair.
2. Check the pressure relief plug on the gear housing cover. Be sure that it is not plugged.
3. Lubricate cable with light oil.

### **B. MONTHLY**

1. Check the winch mounting bolts. If any are missing, replace them and securely tighten any that are loose. Use grade 8 or better bolts.
2. Inspect the cable. If the cable has become frayed with broken strands, replace immediately.

## C. ANNUALLY

1. Drain the oil from the winch annually or more often if winch is used frequently.
2. Fill the winch to the oil level plug with clean kerosene. Run the winch a few seconds with no load in the reel in direction. Drain the kerosene from the winch.
3. Refill the winch to the oil level plug with all purpose SAE 3W-100 gear oil.
4. Inspect bumper and surrounding structure for cracks or deformation.

## TROUBLESHOOTING GUIDE

---

### CONDITIONS

### POSSIBLE CAUSE

### CORRECTION

---

#### OIL LEAKS FROM WINCH

- |                           |  |
|---------------------------|--|
| 1. Seals damaged or worn. | 1. Replace seal.                         |
| 2. Too much oil.          | 2. Drain excess oil. Refer to OPERATION. |
| 3. Damaged gaskets.       | 3. Replace gaskets.                      |
| 4. Damaged o-rings.       | 4. Replace o-rings.                      |
- 

#### WINCH RUNS TOO SLOW

- |                              |  |
|------------------------------|--|
| 1. Low flow rate             | 1. Check flow rate. Refer to HYDRAULIC SYSTEMS performance chart page 3. |
| 2. Hydraulic motor worn out. | 2. Replace motor.  |
- 

#### CABLE DRUM WILL NOT FREESPOOL

- |                          |                                      |
|--------------------------|--------------------------------------|
| 1. Clutch not disengaged | 1. Check operation, refer to page 4. |
|--------------------------|--------------------------------------|
- 

#### BRAKE WILL NOT HOLD

- |  |  |
|--|--|
| 1. Incorrect directional control valve. (Cylinder spool, closed center). | 1. Use only a motor spool (open center) directional control valve. |
|--|--|

## INSTRUCTIONS FOR DISASSEMBLY

1. **NOTE:** Removal of winch from bumper will require 2 persons. Winch must be lowered through the bottom of bumper. Do not attempt to lift winch out through the top of bumper.
2. **NOTE:** Winch must be supported prior to removing winch mounting bolts.
3. Remove (6) capscrews #110 from back side of bumper as shown below. Next remove (4) capscrews # 111 from back side of bumper. Remove (4) capscrews #108 from front side of bumper. Once these capscrews are removed, the winch can be removed from the underside of bumper.

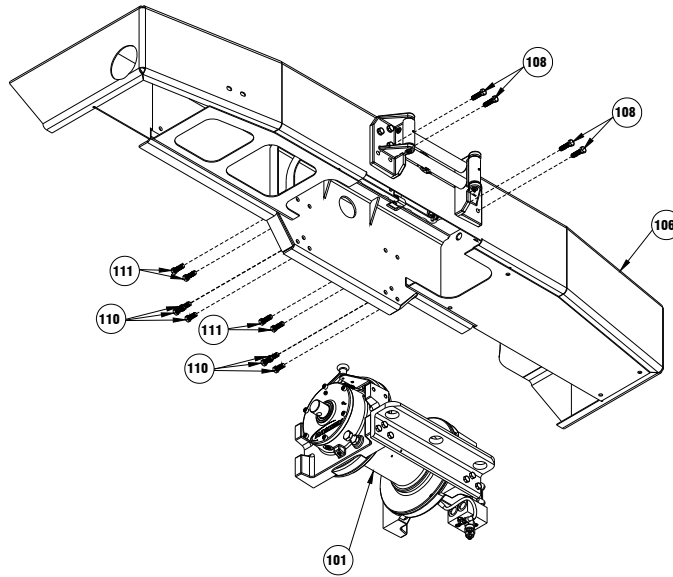



4. Remove vertical roller pin #120 from right hand side of roller guide #102 by removing spring pin #119. Spring pins should be removed by driving inward through the roller. Vertical roller pin has (2) lube fittings #118 located one at either end of the roller. Once the vertical roller pin is removed from right hand side of roller guide, vertical roller #117 can be removed. Remove vertical roller from left hand side of roller guide in the same way.

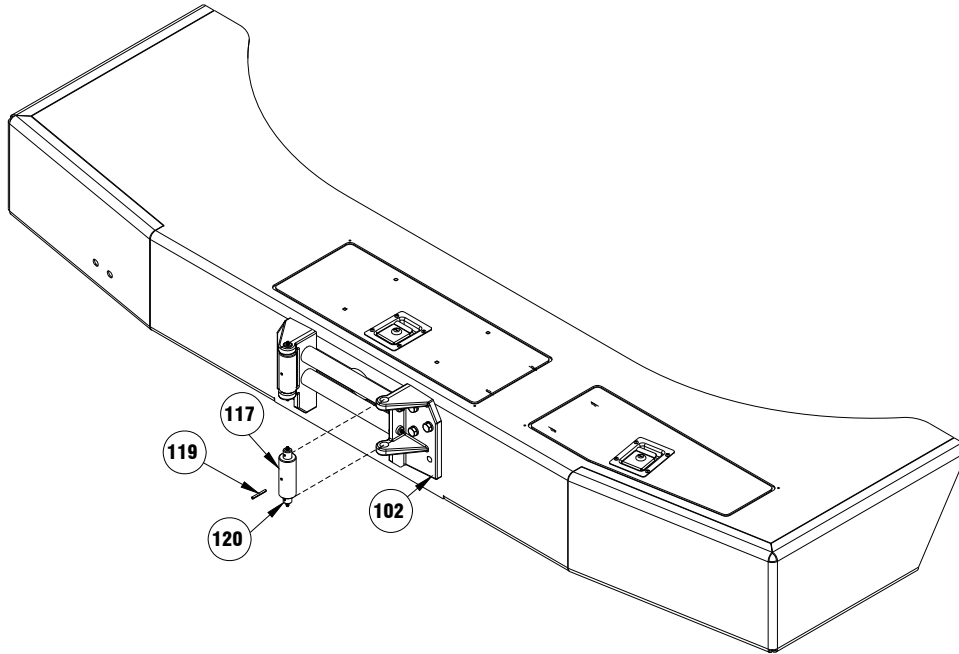

5. The two horizontal rollers #116 are held in place by the roller guides and can now be removed. Each horizontal roller has (2) lube fittings #118, located one at either end of the roller. To remove the right hand roller guide #102, and the left hand roller guide #103 remove (3) capscrews #111, (3) washers #114, and (3) nuts #112 each side.

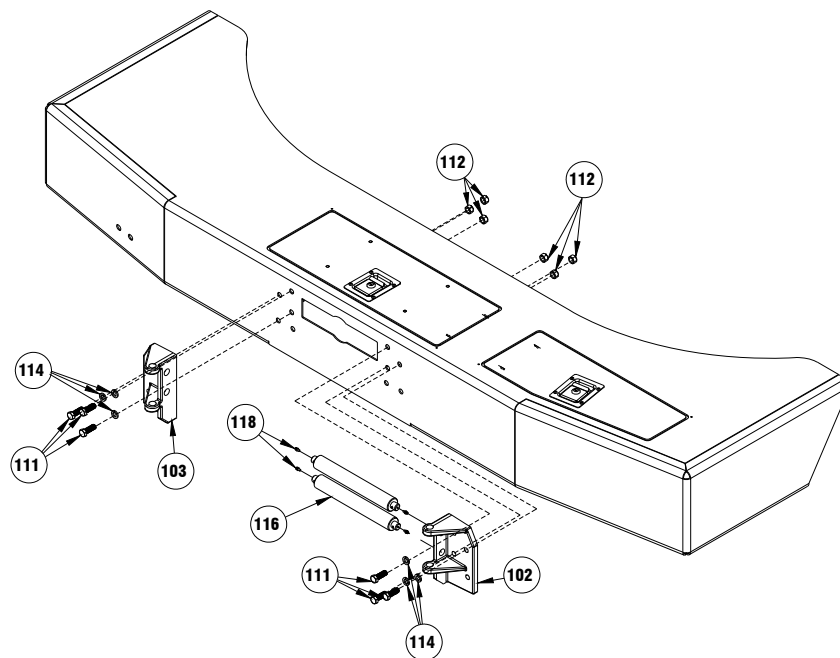

## INSTRUCTIONS FOR OVERHAUL – 20K Powermaster Winch

1. Drain oil from gear housing by removing plug #65 from drain hole in end bearing. **When refilling oil in gear housing, use 16 ounces of SAE +) W-- 0 Gmbh YhW; YUf Cil.**

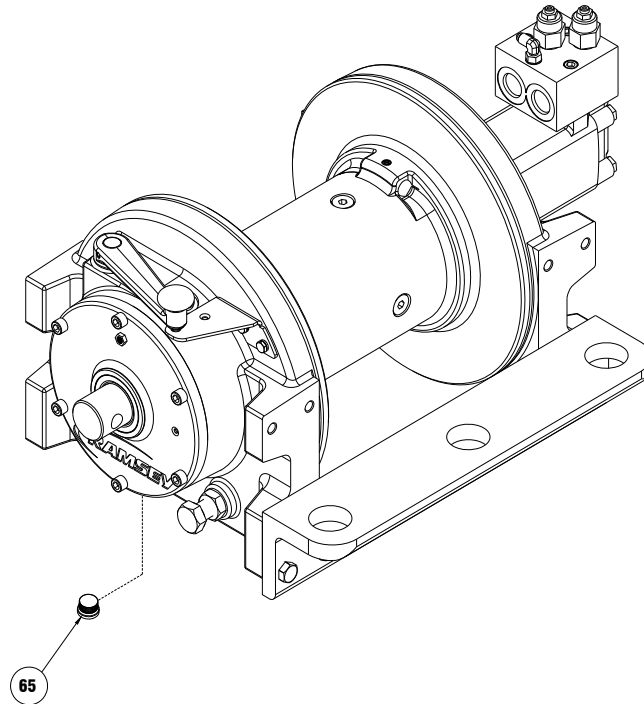

2. Freespool drum to locate drain hole in bottom. Remove plugs #47 from barrel of drum. Drain oil from drum barrel. **When refilling oil in drum, use 16 ounces of SAE +) W-- 0 Gmbh YhW ; YUf C] "ÄJ^ { [ ç^ mounting angle #5 by loosening (3) capscrews #25 each side.**

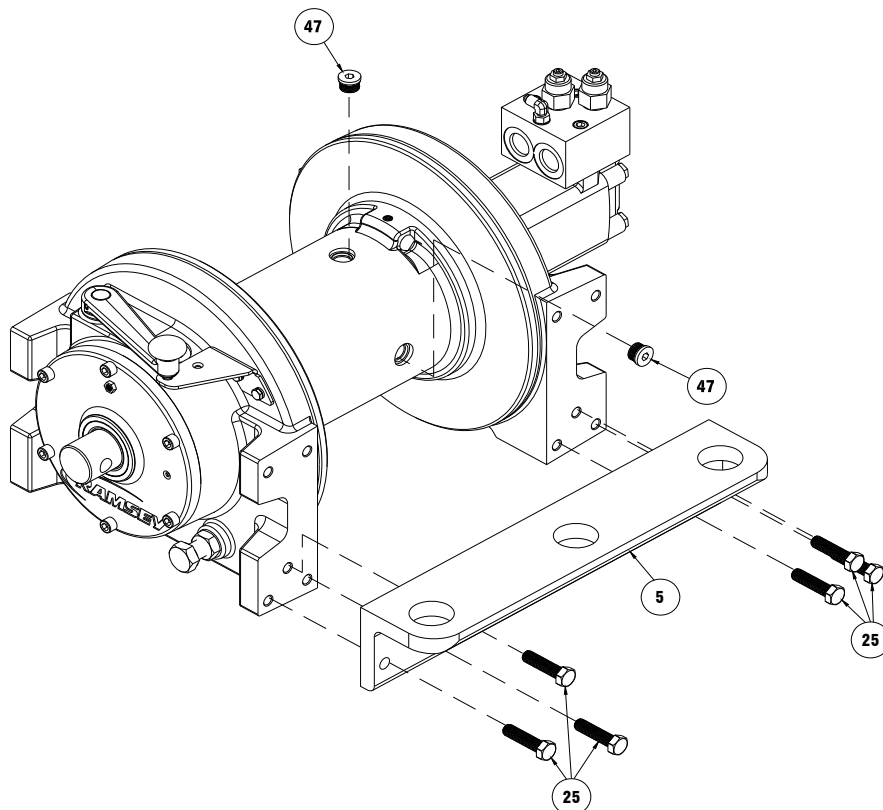

3. Loosen (6) capscrews #27 and remove clutch housing cover #7. Remove relief fitting #36 and plug #46 from clutch housing cover as shown. Remove shaft oil seal #54; also remove clutch housing o-ring #44 and bushing #21. Pull shifter lever away from drum and slide clutch yoke #18 from shaft.

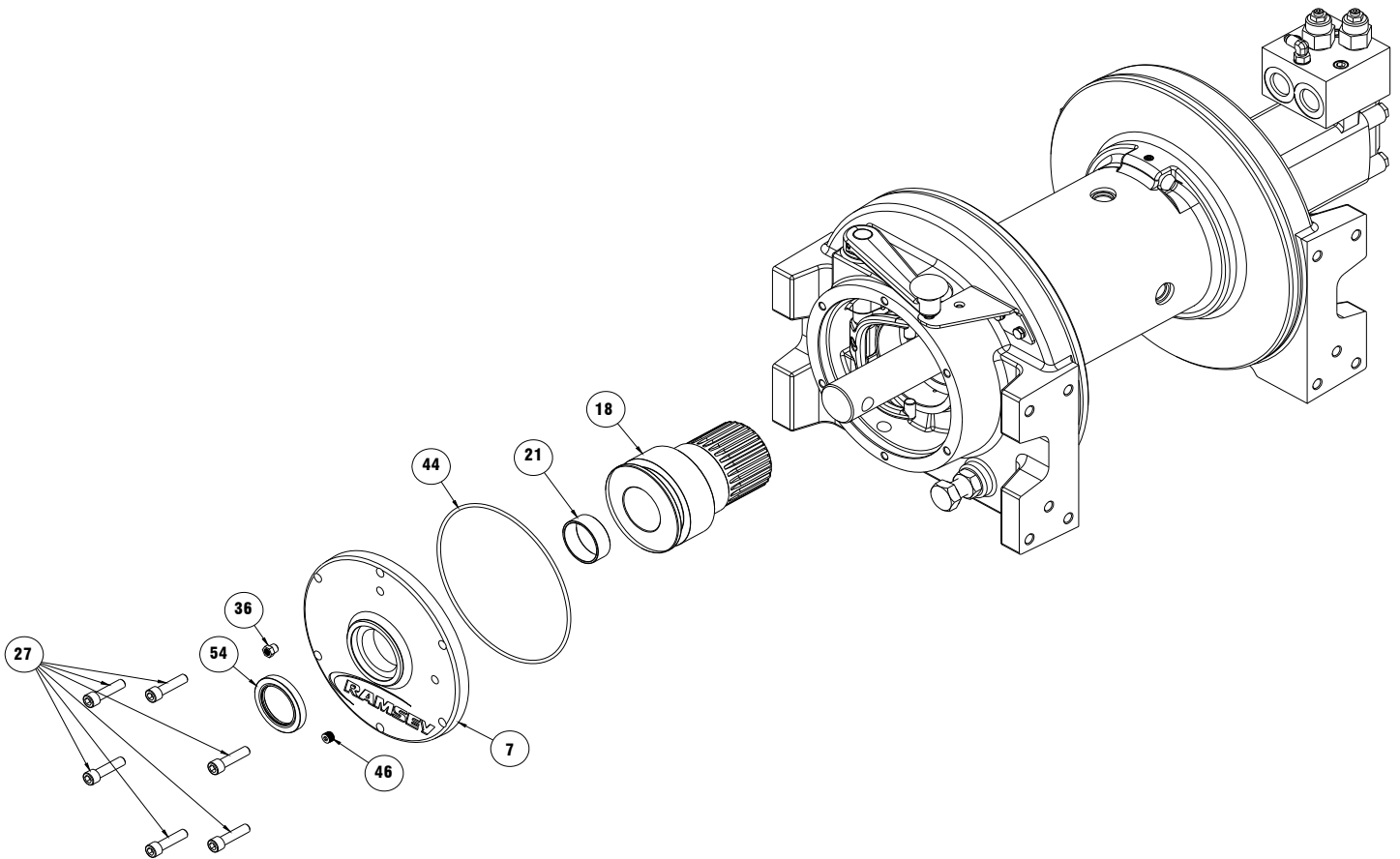

- Slide clutch end bearing #2 from drum. Drum freespool drag puck #12, drum freespool spring # 58, and brake disc spacer # 62 will fall out when end bearing is removed from drum. Retain these items for re-assembly.

To remove shifter yoke #19, drive spring pin #50 inward through shifter yoke. Lift shifter assembly out by pulling up on shifter handle assembly #17 until shifter shaft #15 is clear of shifter yoke #19. Yoke can then be lifted out of end bearing.

To replace handle #17 on shifter shaft #15, first remove spring pin #51, then slide handle assembly #17 from shifter shaft #15. O-ring #45 can be replaced at this time.

To replace shifter detent bracket #20, first remove (2) ¼ x 20 capscrews #23 and (2) ¼ lockwashers # 31, then remove shifter detent bracket #20 and replace.

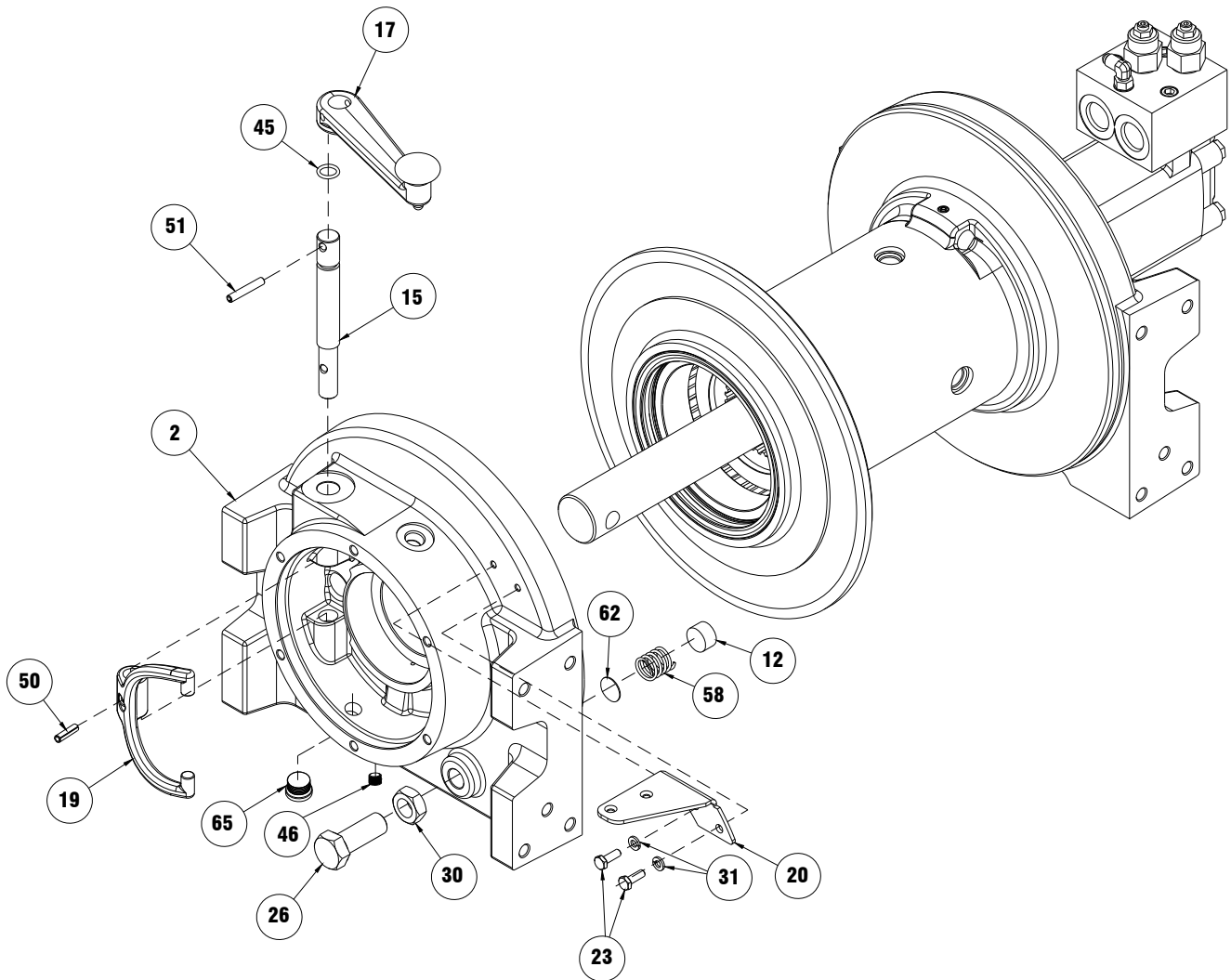

5. Remove drum bushing assembly #22. Note that the (6) spring pins #53 are pressed into the bushing and cannot be removed. To replace the drum bushing, first press in the (6) spring pins #53, and then replace the bushing. Drum seal #55 can also be replaced at this time if needed.

**Note: Replacement bushings do not include the pins so you will need to order them separately.**

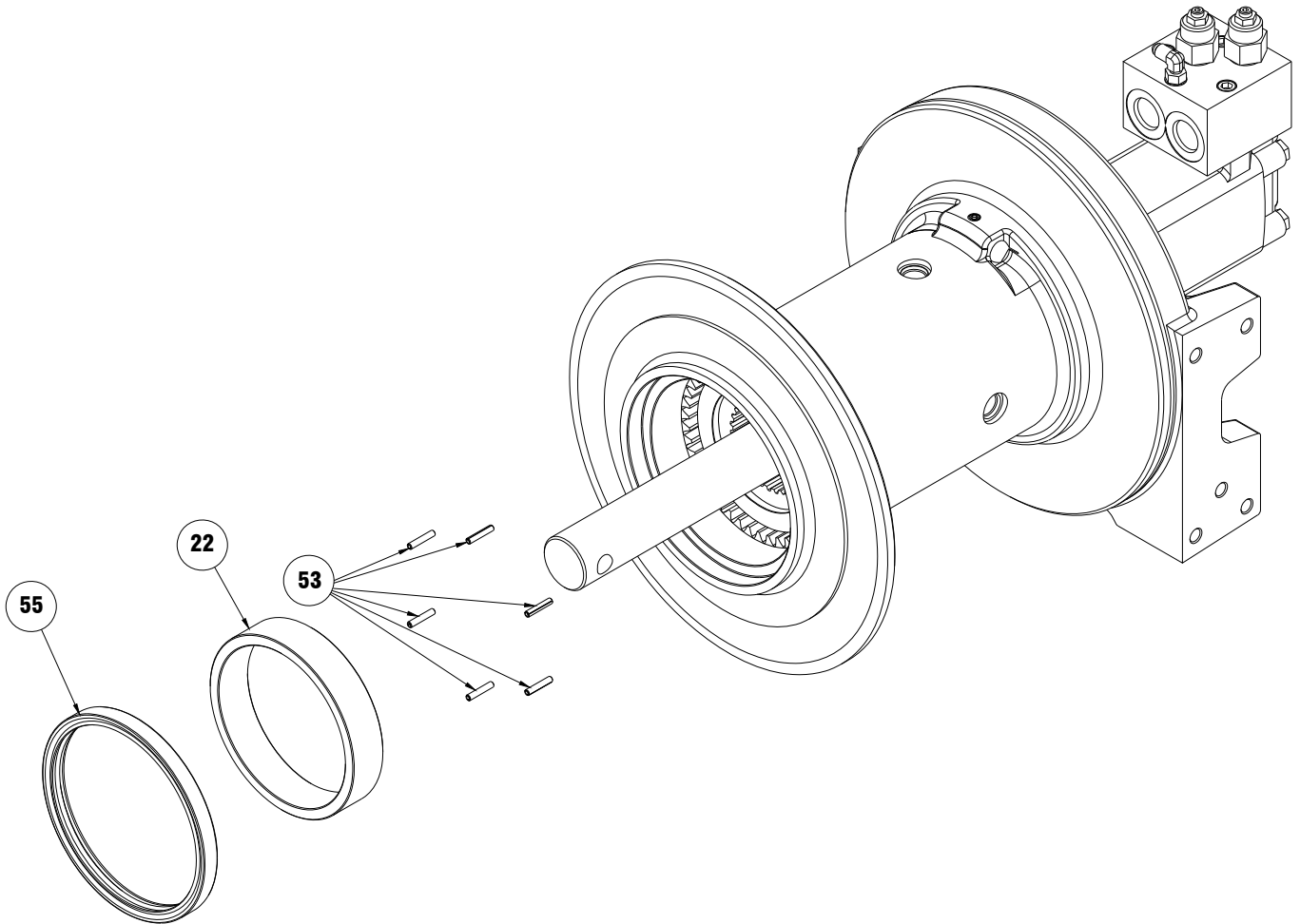

6. Remove output shaft #16, output carrier assembly #1, and input carrier assembly #6 from drum #13. Disassemble in the following order:

Knock (3) spring pins #49 inward to center of input carrier assembly #6. Remove (3) input planet pins #52 from input carrier assembly #6. Remove (3) input planet gears #4 from input carrier assembly #6.

Remove output shaft external retaining ring #57 from output shaft #16. Slide input carrier #6 from output shaft #16.

Remove thrust washer #61 from output shaft #16. Slide output carrier assembly #1 from output shaft #16. Output carrier assembly #1 must be purchased as an assembly. Replacement gears are not available.

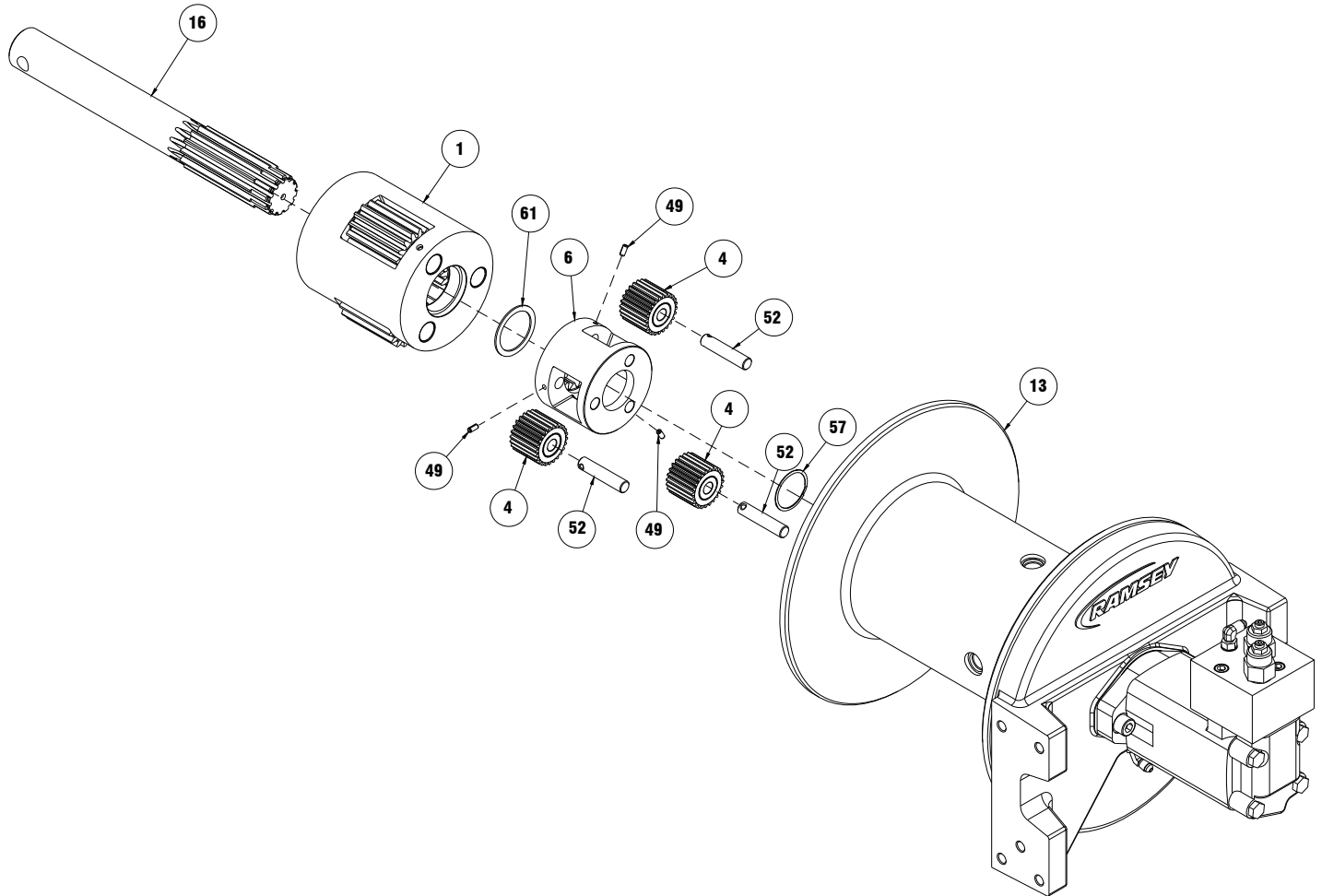

- Remove drum #13 from motor end bearing #3. Remove drum seal #55. Check for signs of wear and replace if necessary.

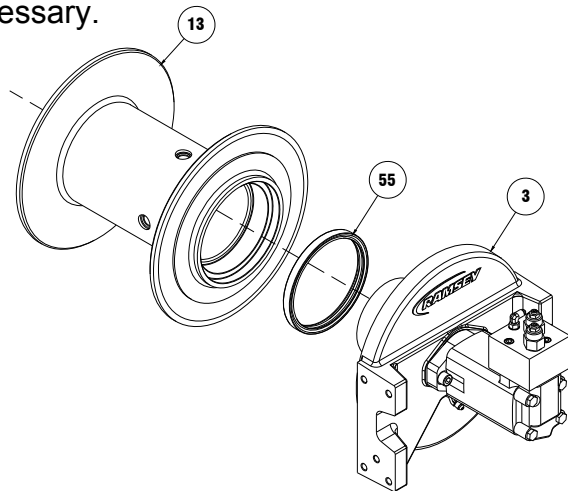

- Remove input shaft #14 from motor end bearing #3.

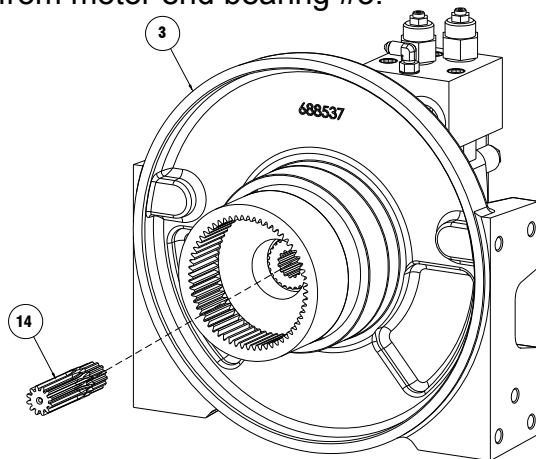

- To remove motor #37 from motor end bearing #3, first detach hydraulic brake release hose assembly #64 from elbow fitting #33 and #34. Loosen (2) 1/2-13 capscrews #24. Remove motor gasket #35, and (11) brake springs #59.
- To remove motor control valve #60, loosen (3) 3/8-16 NC capscrews #28. Lift motor control valve #60 from motor #37.

**Note: Do not run winch with hydraulic brake release hose assembly disconnected.**

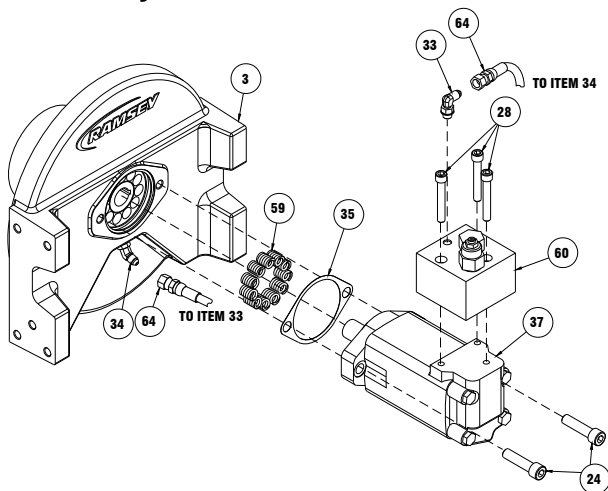

- Remove (2) retaining rings #56. Remove motor coupling #32 from end bearing #3. Remove roll pin #48 from motor coupling #32. Remove brake piston #10 and backup brake piston #11. Remove o-ring #39, o-ring #38, backup ring #41, and backup ring #43 from brake piston #10. Remove o-ring #40 and backup ring #42 from backup brake piston #11. Remove (7) stators #8 and (6) brake discs #9 from end bearing #3.

**To re-install brake,** set gear housing end down on work surface.

Install well-oiled o-rings and backup rings into grooves on outside of brake piston and backup brake piston as shown in cross-section A-A below.

Piston, backup piston, brake discs and stators must be clean and well lubed with  $\ddot{\text{I}} \text{ I}$  W-JO Synthetic Gear oil.

Insert (7) stators #8 and (6) brake discs #9 into gear end alternating, with stators first and last.

Insert backup brake piston #11 on to brake piston #10. Insert brake piston assembly into motor end bearing #3. Apply even pressure on piston when installing.

Insert roll pin #48 into motor coupling #32 below bottom of spline teeth. Insert motor coupling #32 into end bearing #3.

Install (2) retaining rings #56 into grooves in motor end housing.

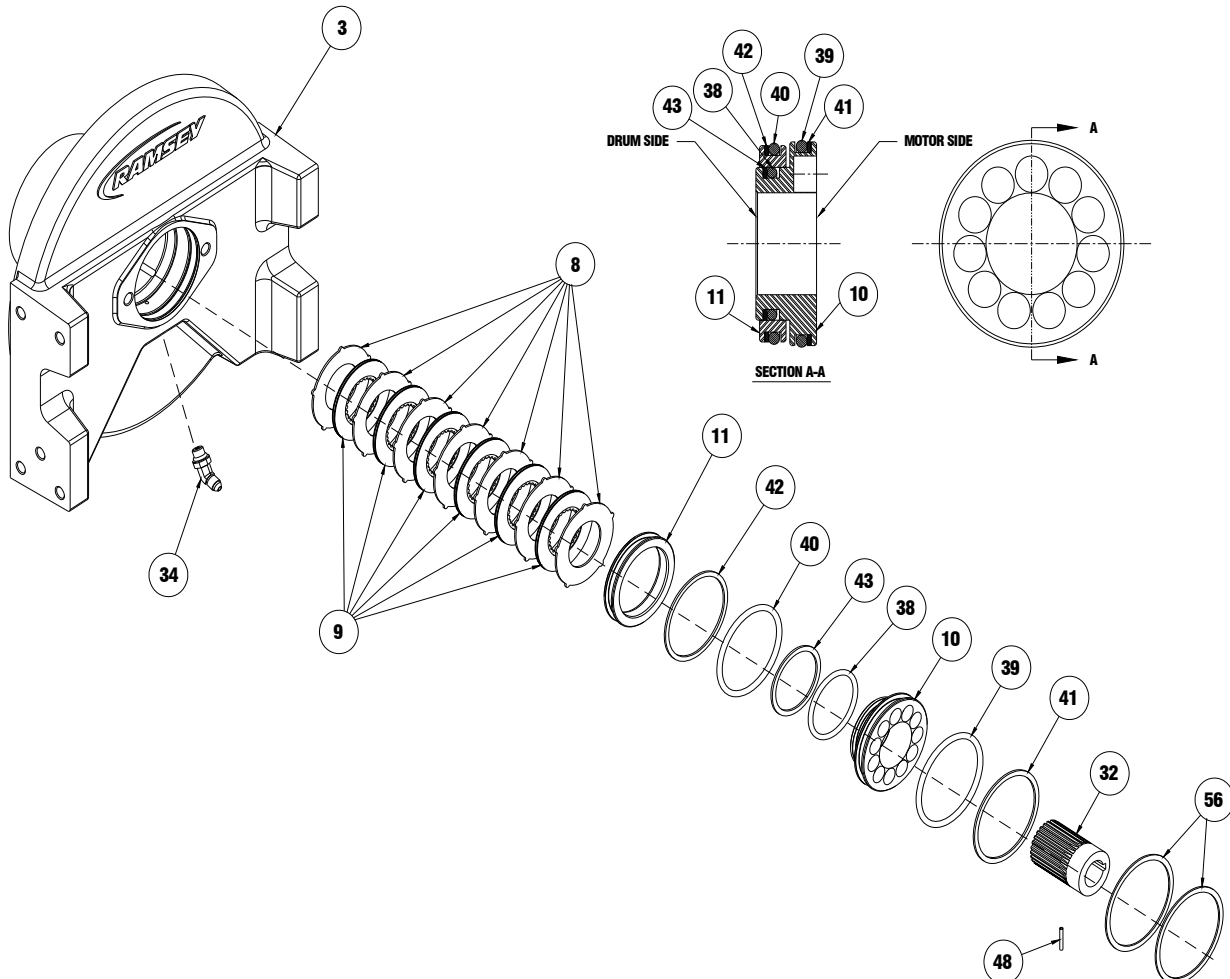



# PARTS LIST – POWERMASTER 20K BUMPER WINCH

15

ITEM	QTY.	PART NO	DESCRIPTION
101	1	296654	20K BUMPER WINCH PORTS DOWN
	1	296680	20K BUMPER WINCH PORTS UP
102	1	333026	ROLLER GUIDE-RH
103	1	333027	ROLLER GUIDE-LH
106	1	410010	BUMPER-BLACK
108	4	414550	BOLT-1/2-13NCX1 3/4LG, HMHD, Z/P, GR.8
110	6	414961	CAPSCREW-1/2-13NC X 1.25 LG HX HD GR8 Z/P
111	10	414512	CAPSCREW-1/2-13NC X 1.25 LG HX HD GR8 Z/P
112	6	418069	NUT-1/2-13NC HEX REG, ZINC PLATED
114	6	418218	LOCKWASHER-1/2 ID MED SECT, ZINC PLT
116	2	424033	ROLLER-HORIZONTAL
117	2	424034	ROLLER-VERTICAL
118	8	456001	LUBE FITTING
119	2	470105	SPRING PIN
120	2	470109	VERTICAL ROLLER PIN

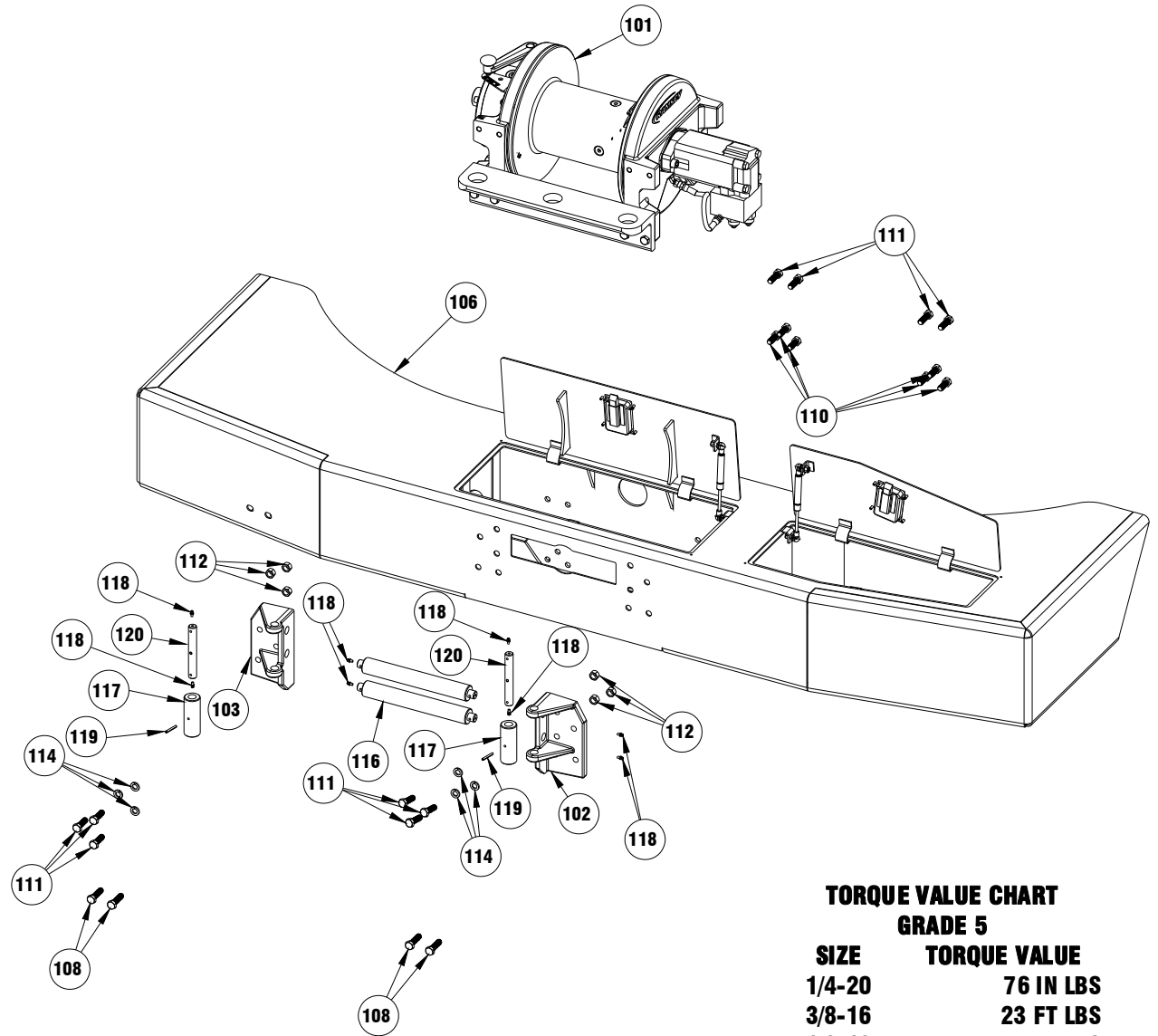

**TORQUE VALUE CHART**

**GRADE 5**

SIZE	TORQUE VALUE
1/4-20	76 IN LBS
3/8-16	23 FT LBS
1/2-13	57 FT LBS
3/4-16	223 FT LBS

**GRADE 8**

SIZE	TORQUE VALUE
1/2-13	80 FT LBS
5/8-11	159 FT LBS

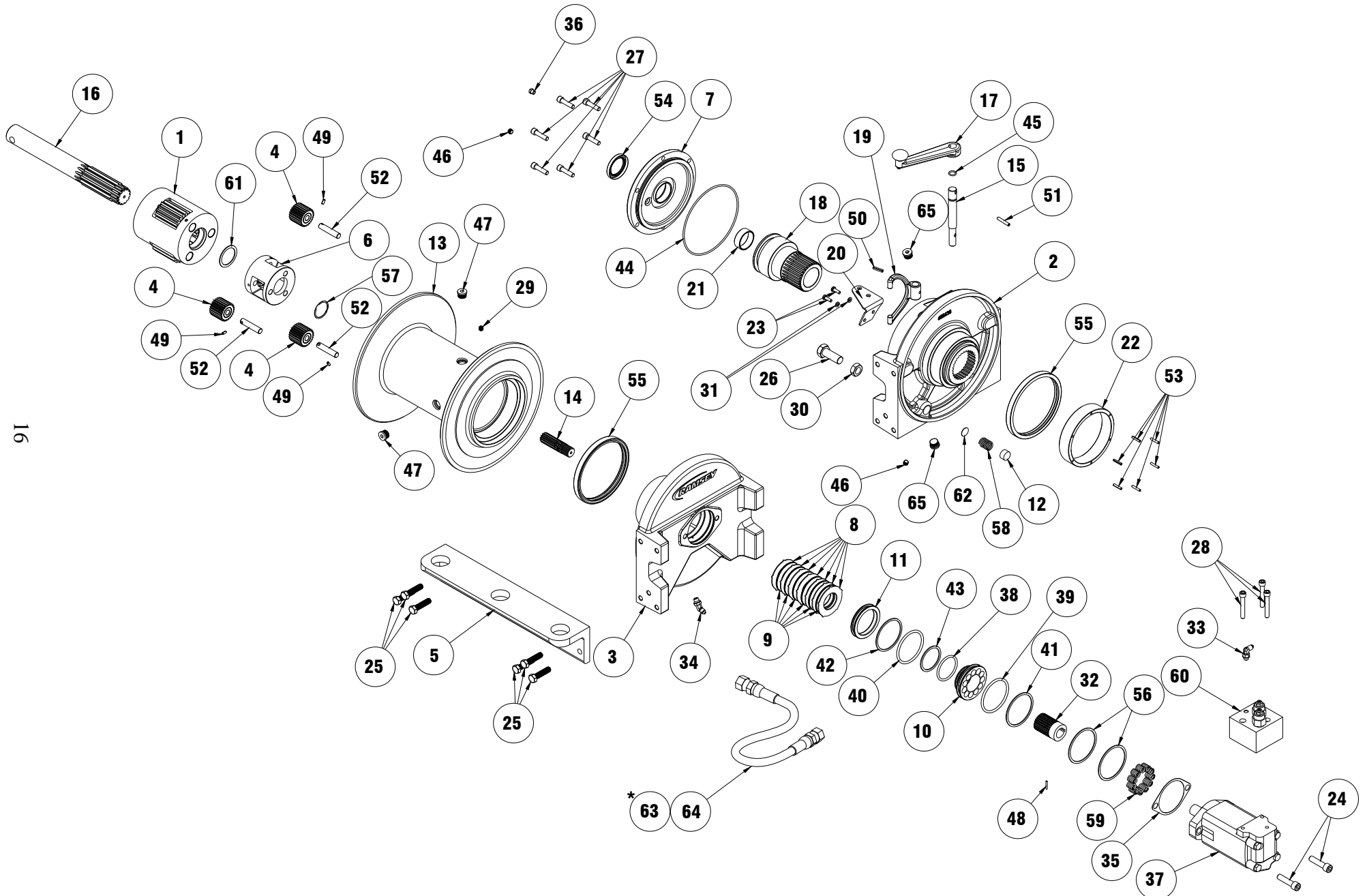

**POWERMASTER  
20K BUMPER WINCH**

**\* CONFIRM MOTOR PORTS UP OR MOTOR PORTS DOWN  
FOR CORRECT HOSE ASSEMBLY**

**PARTS LIST – POWERMASTER 20K BUMPER WINCH**

<b>ITEM</b>	<b>QTY.</b>	<b>PART NO</b>	<b>DESCRIPTION</b>	<b>ITEM</b>	<b>QTY.</b>	<b>PART NO</b>	<b>DESCRIPTION</b>
1	1	247040	OUTPUT CARRIER	33	1	432018	FITTING-90 DEGREE ELBOW, -4 SAE ORING TO -4 JIC
2	1	296673	CLUTCH END BEARING	34	1	432044	FITTING-45 DEGREE ELBOW, -4 SAE ORING TO -4 JIC
3	1	296674	MOTOR END BEARING	35	1	442223	GASKET-MOTOR
4	3	296675	INPUT PLANET GEAR ASSEMBLY	36	1	456008	RELIEF FITTING
5	1	303127	ANGLE-TOW	37	1	458144	MOTOR-HYD (14.9) CU IN 1" SHAFT
6	1	317015	CARRIER-INPUT	38	1	462067	O-RING-2.225 ID X .210 THK, 2-331
7	1	328166	COVER-CLUTCH HOUSING	39	1	462068	O-RING-3.10 ID X .210 THK, 2-338
8	7	330011	STATOR-BRAKE	40	1	462069	O-RING-2.975 ID X .210 THK, 2-337
9	6	330012	DISC-BRAKE FRICTION	41	1	462070	RING-BACKUP, 3.143 ID X .076 THK, 8-338
10	1	330013	PISTON-BRAKE	42	1	462071	RING-BACKUP, 3.018 ID X .076 THK, 8-337
11	1	330014	PISTON-BACKUP BRAKE	43	1	462072	RING-BACKUP, 2.268 ID X .076 THK, 8-331
12	1	330015	PUCK-DRAG, DRUM FREESPOOL	44	1	462077	O-RING-6.984 ID X .139 THK, 2-262, CLUTCH HSG CVR
13	1	332231	DRUM-MACHINED	45	1	462078	O-RING-.549 ID X .103 THK, 2-113, SHIFTER SHAFT
14	1	355139	SHAFT-INPUT	46	2	468016	PLUG-PIPE 1/8-27NPTF SOC HD
15	1	355141	SHAFT-SHIFTER	47	2	468041	PLUG, -8 SAE, 3/4"-16 UNF
16	1	355144	SHAFT-OUTPUT	48	1	470033	SPIROL PIN
17	1	296682	SHIFT LEVER ASSEMBLY	49	3	470060	SPRING PIN-3/16 X 1/2 LG
18	1	370065	CLUTCH-YOKE	50	1	470103	PIN-SPRING, .25 X 1.0 LG
19	1	370061	YOKE-SHIFTER	51	1	470104	PIN-SPRING, .25 X 1.5 LG
20	1	408364	BRACKET-SHIFTER DETENT	52	3	470107	PIN-INPUT PLANET
21	1	412115	BUSHING-CLUTCH HOUSING COVER	53	6	470123	PIN-SPRING, .188 X 1.00 LG
22	1	412132	BUSHING-DRUM	54	1	486066	SEAL-SHAFT OIL
23	2	414038	CAPSCREW-1/4-20NC X .75 LG HX HD GR5 Z/P	55	2	486093	SEAL-DRUM
24	2	414511	CAPSCREW-1/2-13 X 2.0 LG SOC HD	56	2	490049	RING-INTERNAL RETAINING
25	6	414513	CAPSCREW-1/2-13UNC X 2.00 LG HX HD GR8 Z/P	57	1	490061	RING-EXTERNAL RETAINING, OUTPUT SHAFT
26	1	414772	CAPSCREW-3/4-16NF X 2.0 LG HX HD GR5	58	1	494002	SPRING-DRUM FREESPOOL
27	6	414906	CAPSCREW-3/8-16NC X 1.5 LG SOC HD F/B	59	11	494124	SPRING-BRAKE
28	3	414935	CAPSCREW-3/8-16NC X 2.5 LG SOC HD	60	1	516011	VALVE-MOTOR CONTROL
29	1	416057	SETSCREW-3/8-16NCX3/8LG,HX SOCHD CU	61	1	518071	THRUST WASHER
30	1	418098	NUT-3/4-16NF HEX JAM	62	1	530094	SPACER-BRAKE DISC
31	2	418149	LOCKWASHER-1/4 MED SECTION,ZINC PLT	63	1	509130	HOSE ASSEMBLY - PORTS DOWN
32	1	431023	COUPLING-MOTOR	64	1	509142	HOSE ASSEMBLY - PORTS UP
				65	2	468018	PLUG - 3/8" -18 NPTF HX SOC



# POWERMASTER<sup>TM</sup> SERIES

By 

## Limited Warranty

RAMSEY WINCH warrants each new RAMSEY WINCH to be free from defects in material and workmanship for a period of one (1) year from date of purchase.

The obligation under this warranty, statutory or otherwise, is limited to the replacement or repair at the Manufacturer's factory, or at a point designated by the Manufacturer, of such part that shall appear to the Manufacturer, upon inspection of such part, to have been defective in material or workmanship.

This warranty does not obligate RAMSEY WINCH to bear the cost of labor or transportation charges in connection with the replacement or repair of defective parts, nor shall it apply to a product upon which repair or alterations have been made, unless authorized by Manufacturer, or for equipment misused, neglected or which has not been installed correctly.

RAMSEY WINCH shall in no event be liable for special or consequential damages. RAMSEY WINCH makes no warranty in respect to accessories such as being subject to the warranties of their respective manufacturers.

RAMSEY WINCH, whose policy is one of continuous improvement, reserves the right to improve its products through changes in design or materials as it may deem desirable without being obligated to incorporate such changes in products of prior manufacture.

If field service at the request of the Buyer is rendered and the fault is found not to be with RAMSEY WINCH's product, the Buyer shall pay the time and expense to the field representative. Bills for service, labor or other expenses that have been incurred by the Buyer without approval or authorization by RAMSEY WINCH will not be accepted.

*See warranty card for details.*



**Ramsey Winch Company**

Post Office Box 581510

Tulsa, Oklahoma 74158-1510

Telephone: (918) 438-2760 FAX: (918) 438-6688

OM-914246-1209-A